

Tubular Solenoid (Model M115)

MT50205

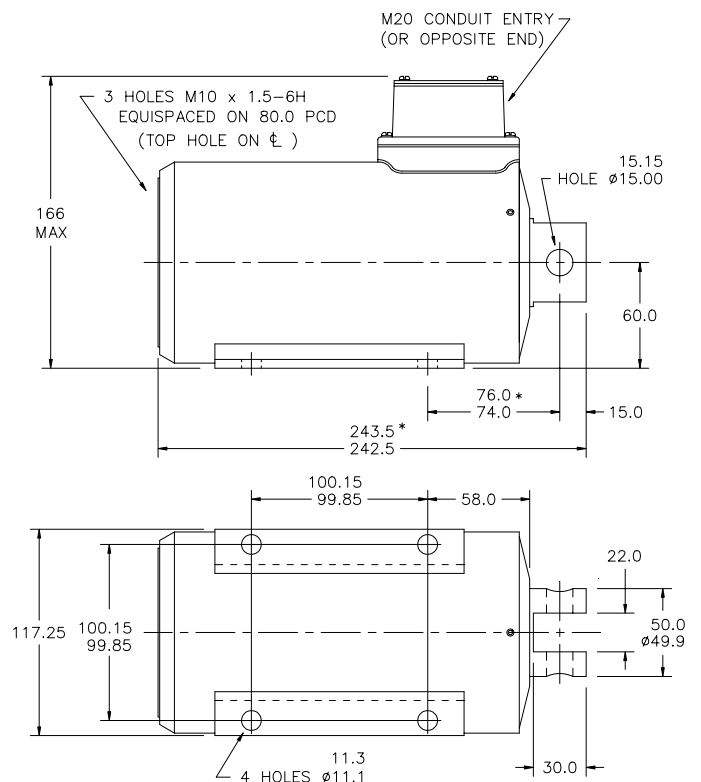

- High Force / Long Stroke
- Fully Enclosed Construction with Potted Coil
- Pull & Thrust Options
- Anti-Residual Disc as Standard
- Alternative Finishes
- Alternative Terminations Available
- Optional Return Springs

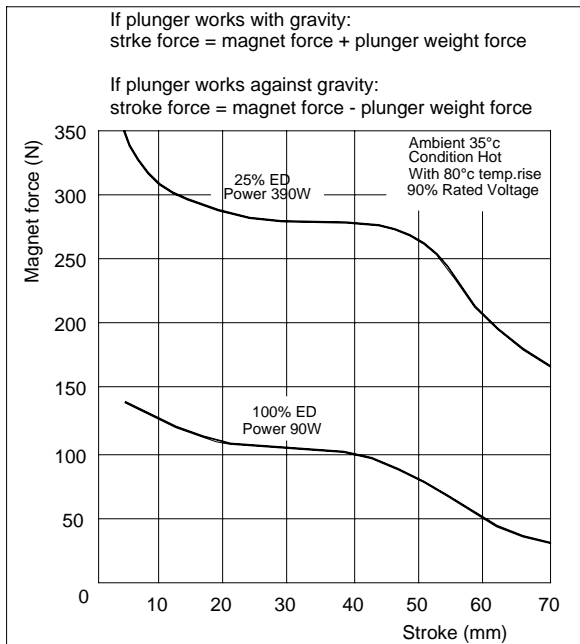

* DIMENSIONS WITH SOLENOID ENERGISED. TOLERANCES (UNLESS STATED) ±0.25mm.